

# 920 Dual Roll Powered Unwind



## Features

- Provides continuous labeler operation during supply roll changes
- Large label accumulation bin and table allow on-the-fly label splicing
- Low-label roll detection with level adjustment, alarm, and light notify operator when roll change is needed
- End-of-roll detection with alarm, light, and applicator inhibit function
- Analog unwind-loop controls provide consistent web tension and smooth operation
- Side-by-side roll design limits operator lifting height of heavy rolls
- Heavy-duty aluminum and stainless steel construction NEMA 12 electrical enclosure

## 920 Dual Roll Powered Label Unwind System

The Model 920 Unwind will improve your production capacity by removing the need to stop when loading new labels as well as increasing the roll size that can be run. When a label roll gets low, the system alarm warns the operator that service is required. The operator can then jog the rest of the label roll into a holding bin, providing a buffer to feed the applicator while splicing a new roll. The jog stops when the end of the roll appears on the work table. Using these features, a trained operator can splice-in a new roll in seconds and never stop your production line.

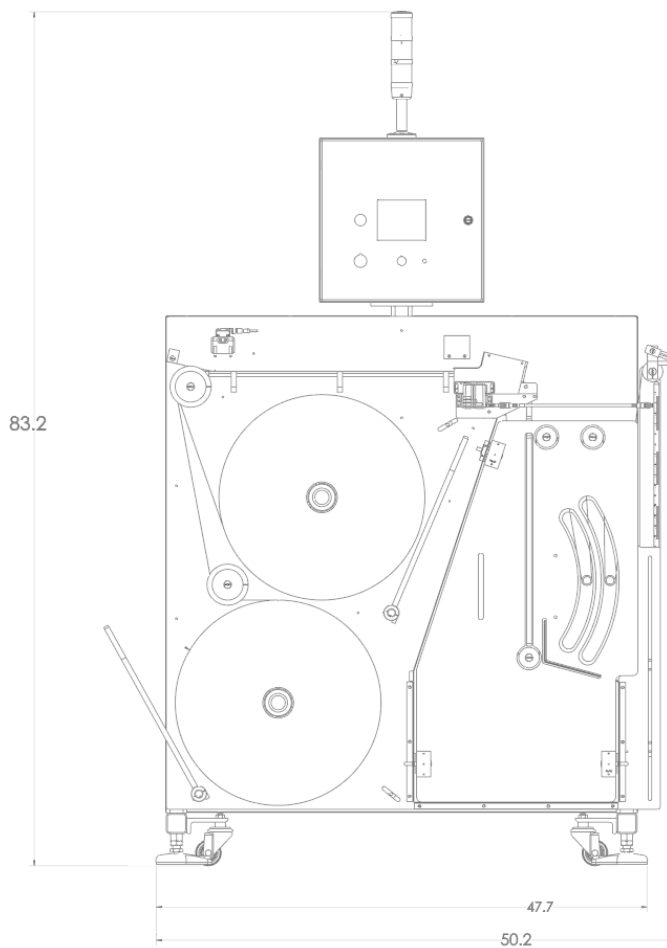
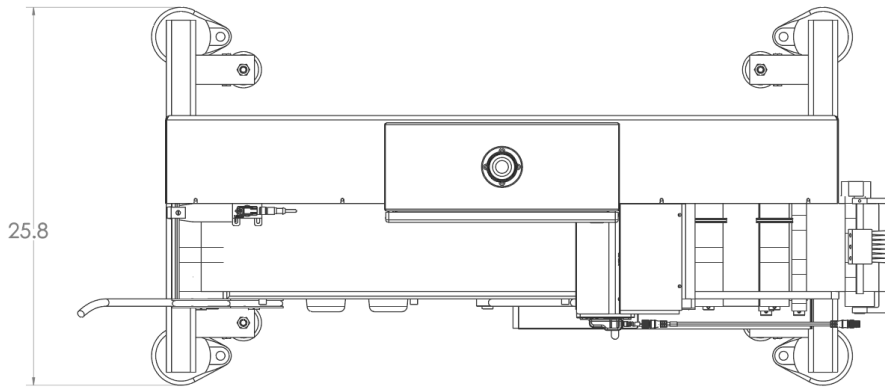

Label Capacity	Maximum Width: 6.50" (165 mm) Roll Size-O.D.: 20" (508mm) Core Size-I.D.: 3" (76mm)
Web Unwind Speed	Variable speed to 3000 inches per minute
Electrical Requirements	120VAC 60HZ 1PH

Accraply | Trine | Stanford | Graham & Steevit | Harland

Accraply

9350 W Broadway Avenue, Suite 190  
Minneapolis, MN 55445 USA

+1 (763) 557-1313  
[accraply.com](http://accraply.com)

barrywehmler  
**bw**  
betterworld